

SilverLine

SLK043 LIGIER FORD JS11 ARGENTINE/SPANISH G.P. 1979 J. Laffite - P. Depailler

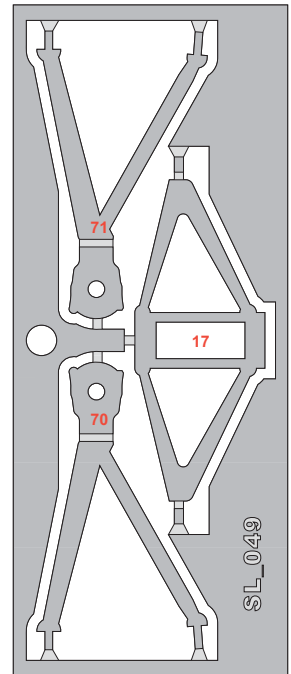

1

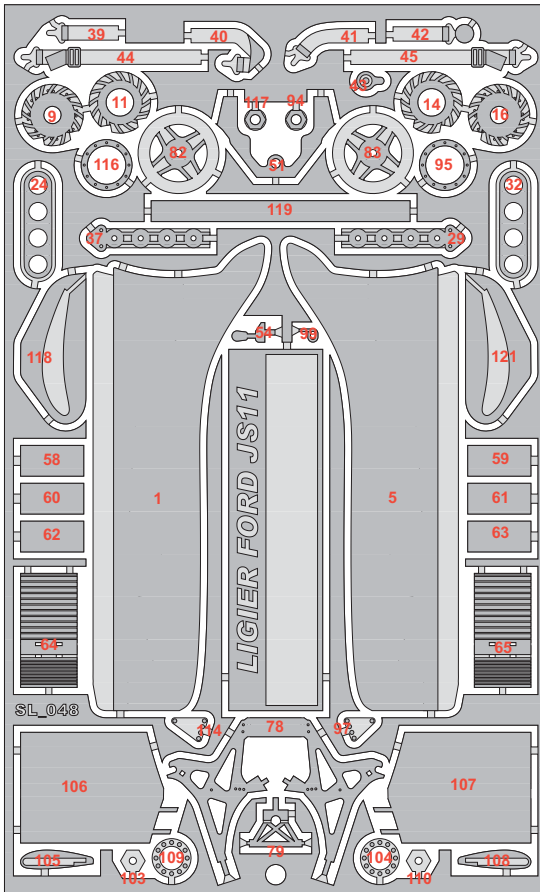
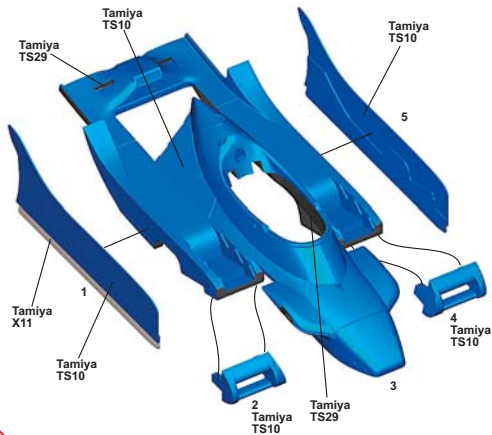

2

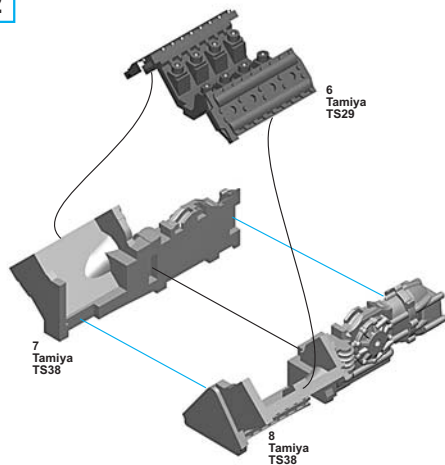

3

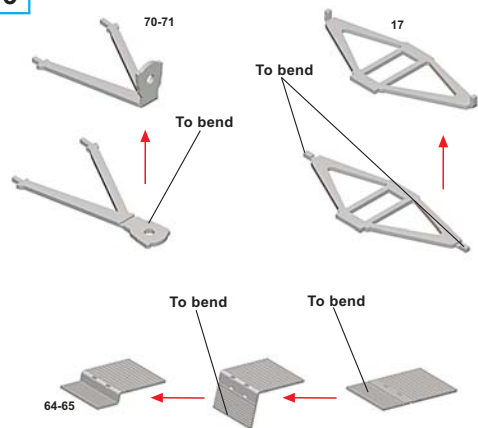

4

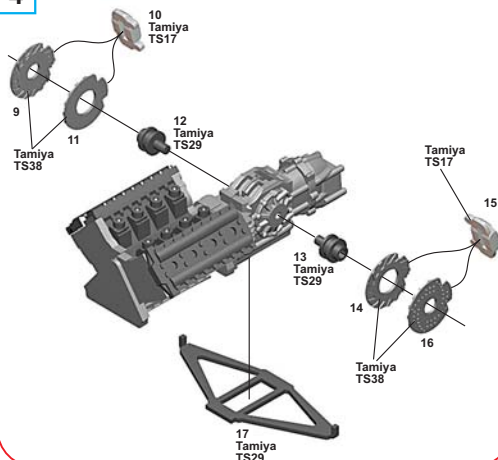

5

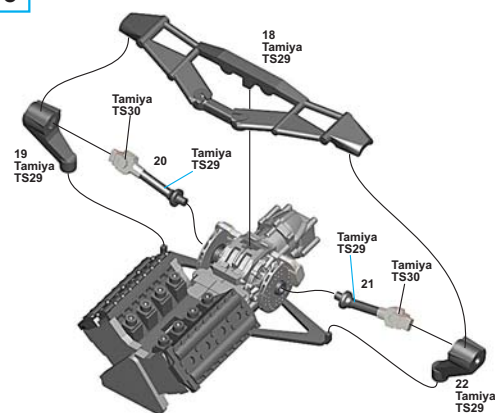

6

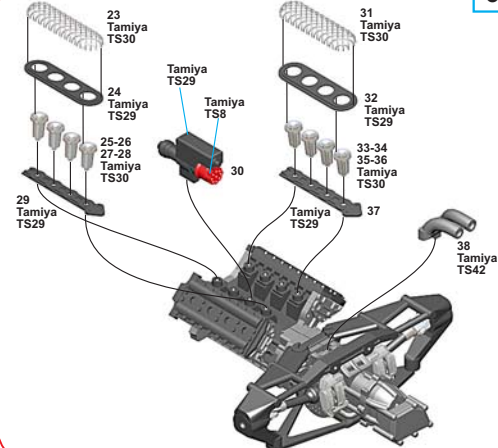

7

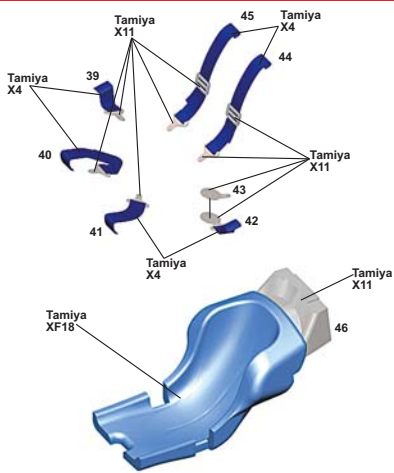

8

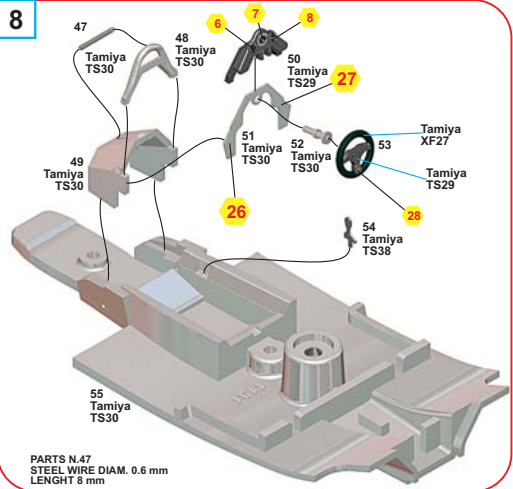

PARTS N.47
STEEL WIRE DIAM. 0.6 mm
LENGHT 8 mm

9

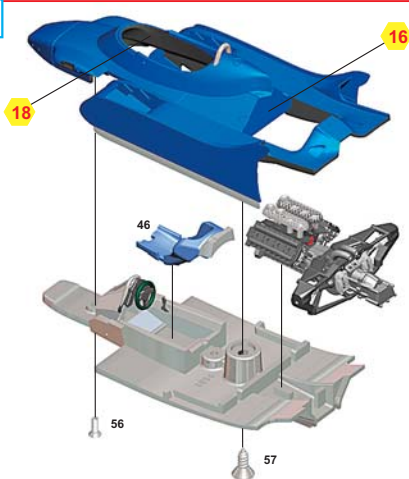

10

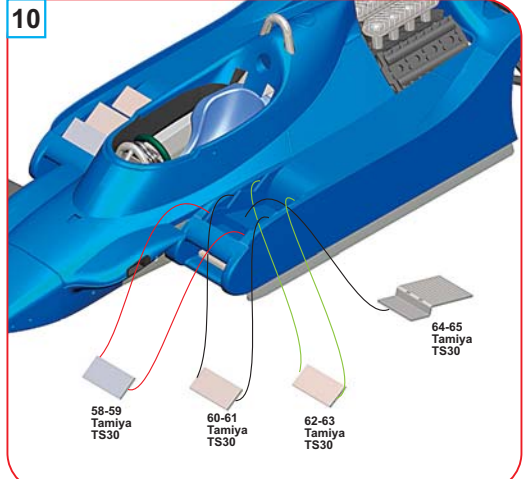

11

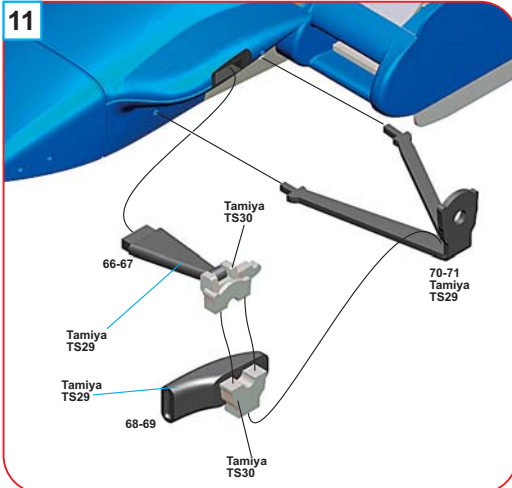

12

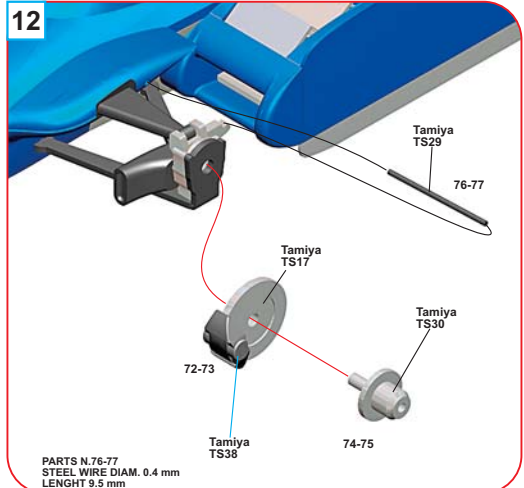

PARTS N.76-77
STEEL WIRE DIAM. 0.4 mm
LENGHT 9.5 mm

13

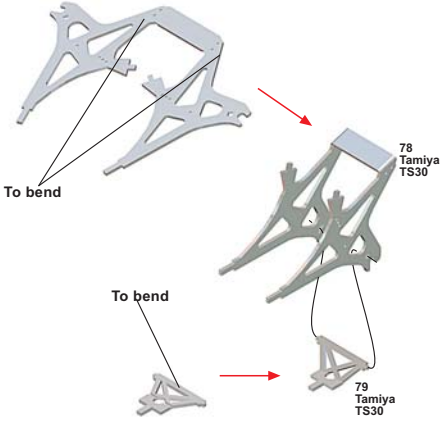

14

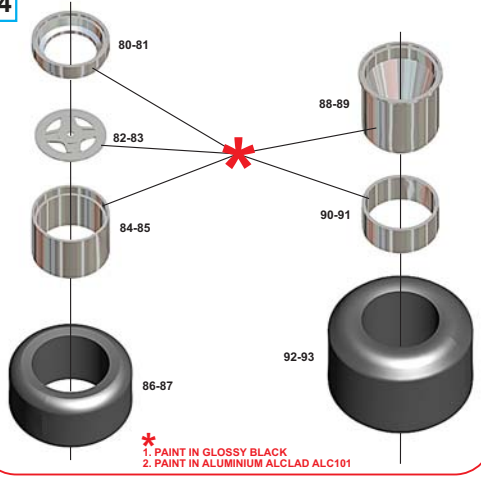

15

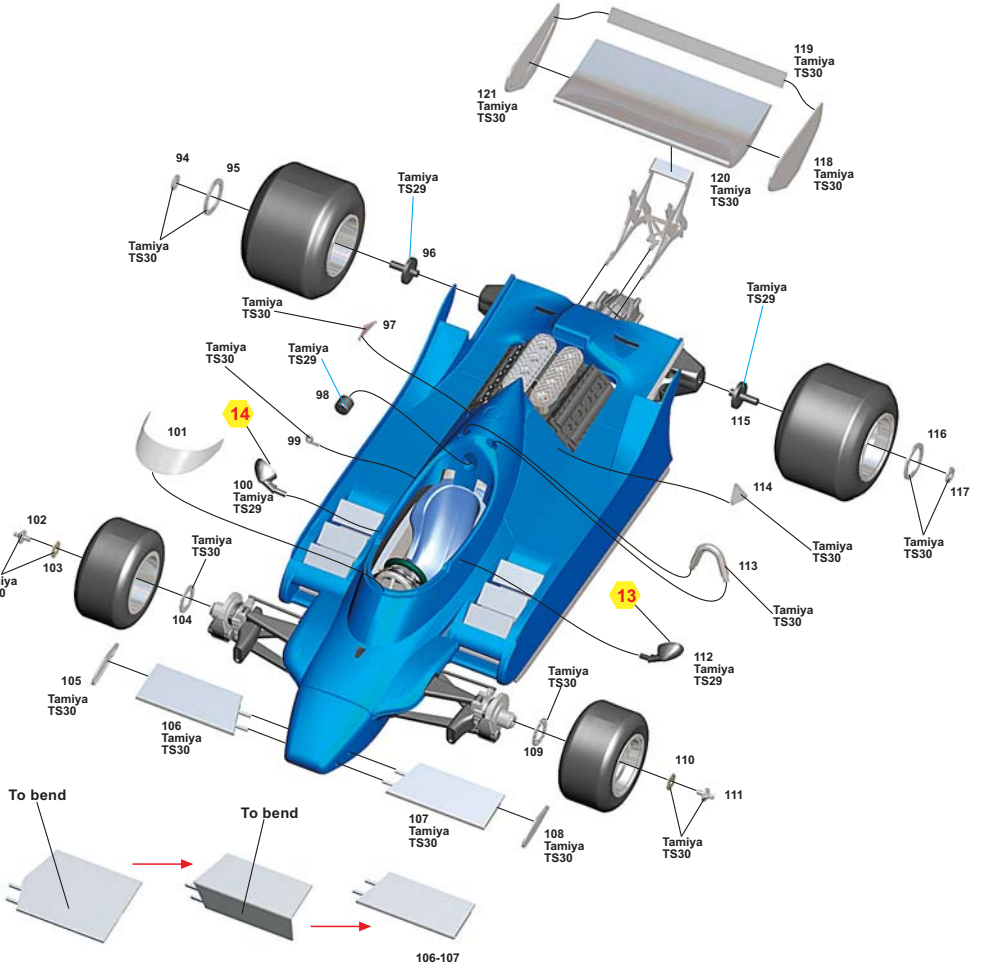

SLK043 LIGIER FORD JS11 ARGENTINE G.P. 1979

N°26 J. Laffite 1ST

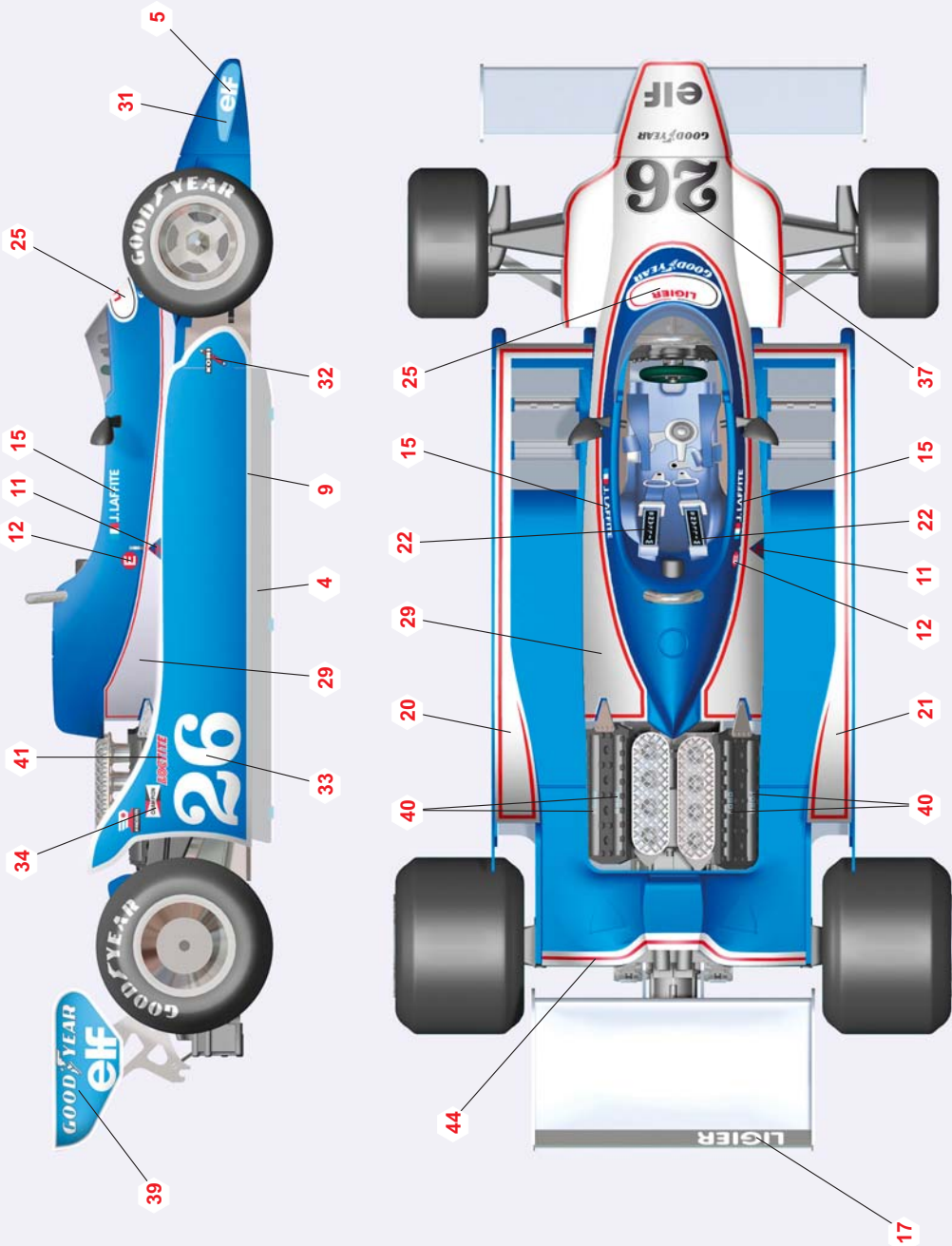

SPANISH G.P. 1979
N°25 P. Depailler 1ST

