

1/43rd Scale White Metal Kit Collectors model. Not suitable for small children

TWU044

Parnelli VPJ4B

Produced with the approval of the Vel's Parnelli Jones Collection



1976 US West GP Mario Andretti - Ret

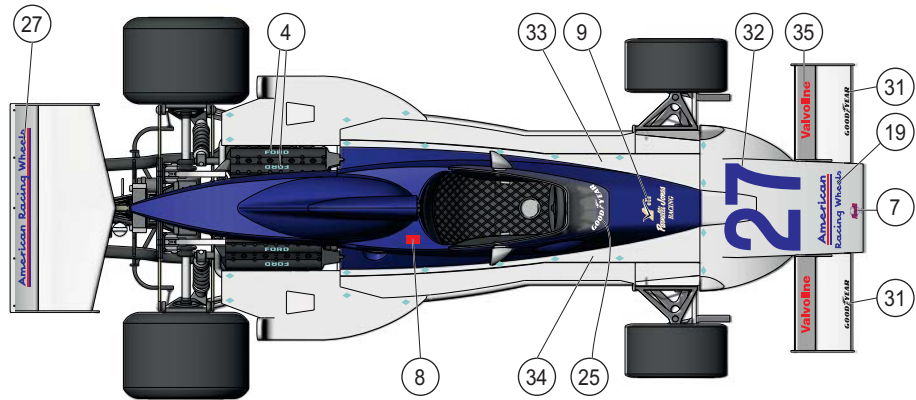
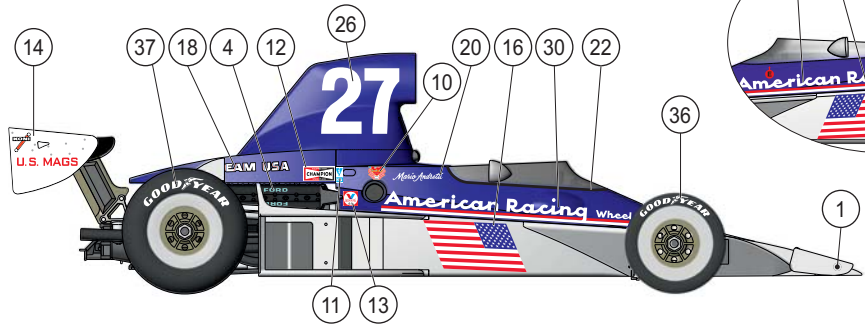
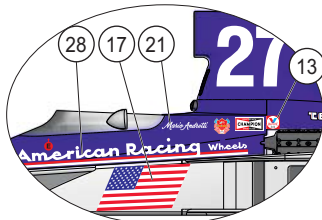

The 1976 US Grand Prix at Long Beach was the 16th and last Formula 1 Grand Prix contested by Vel's Parnelli Jones Racing. Unfortunately Mario Andretti had to retire from the race due to a water leak.

After the radical body changes seen at the South African Grand Prix, in silhouette it again resembled the late 1975 car. The side radiators and nose cone remained the same as in South Africa, but now the 1975 red cockpit surround and air box were blue in the colours of sponsor, American Racing Wheels.

As in South Africa the longer wheel base remained and dampers with coil springs were used all round.

Suspension was upper and lower links with torsion bars at the rear and double wishbone with torsion bars at the front. The brakes were inboard at the rear and outboard at the front.

Paint

- TS15 blue
- TS26 white
- X10 gun metal
- X11 silver
- X18 semi gloss black
- X31 titanium gold
- XF1 flat black
- XF2 flat white
- XF8 flat blue
- XF16 aluminium
- XF56 metallic grey

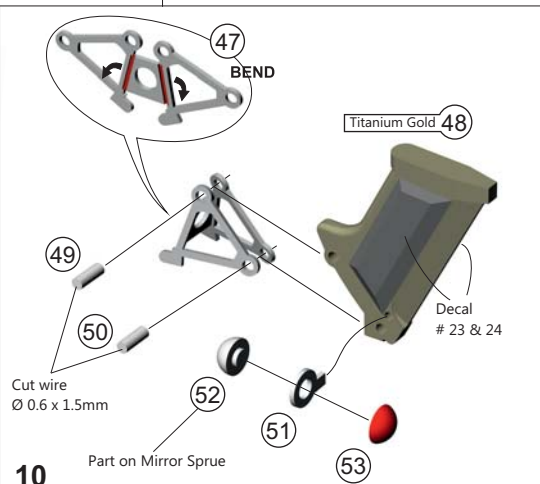
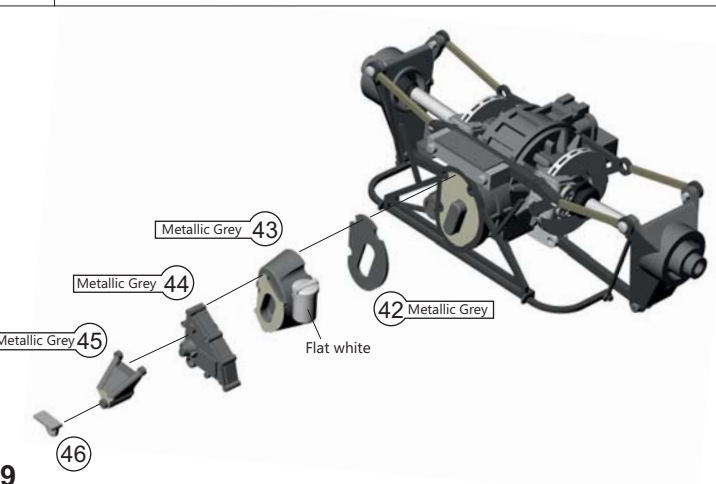
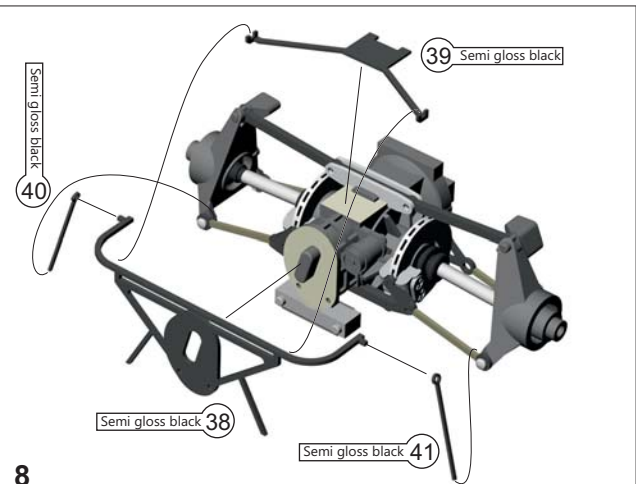
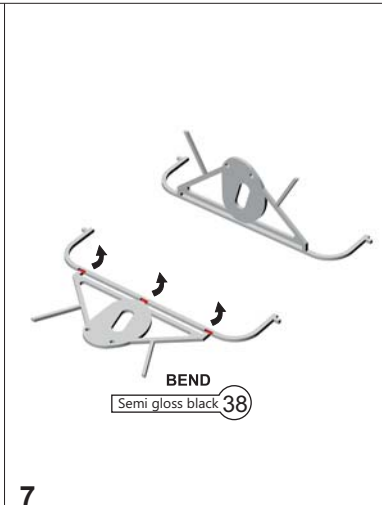
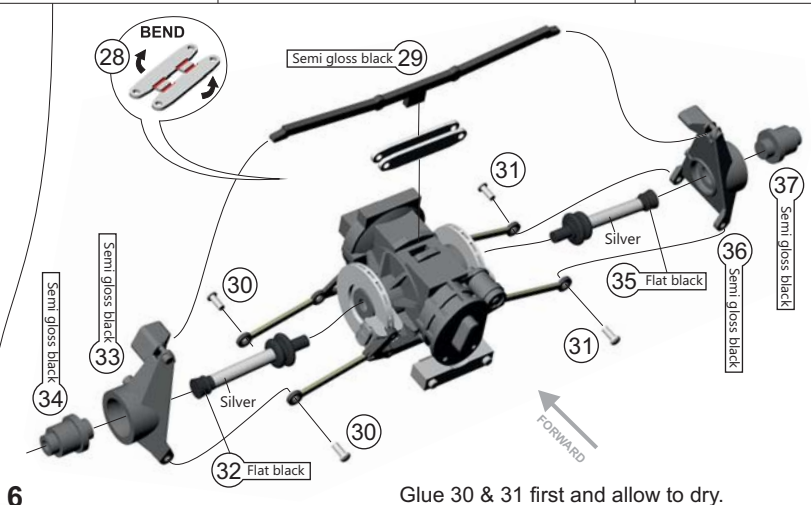
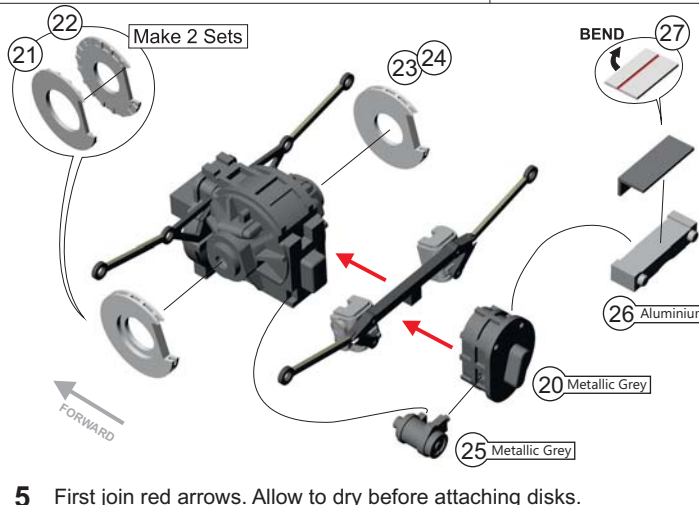
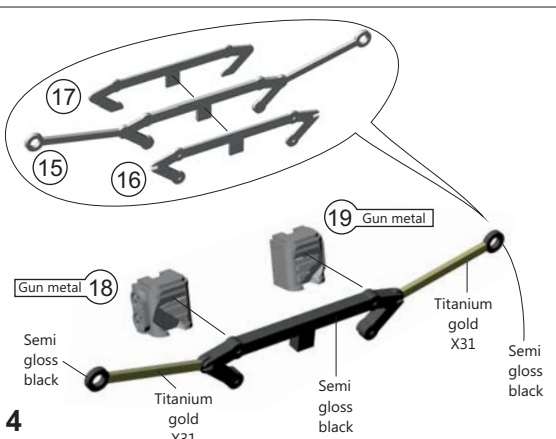
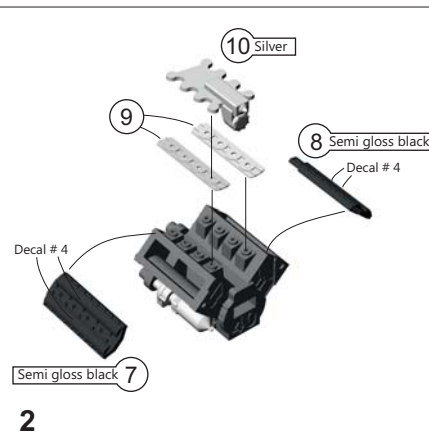
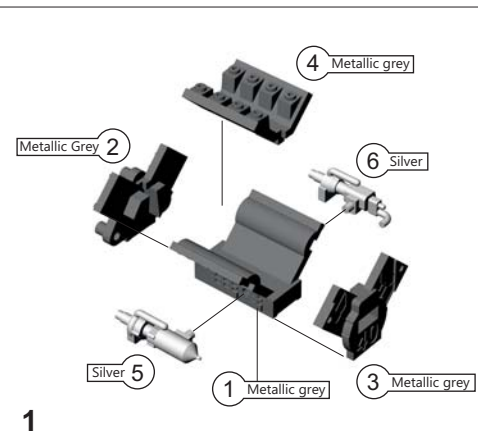

Drill

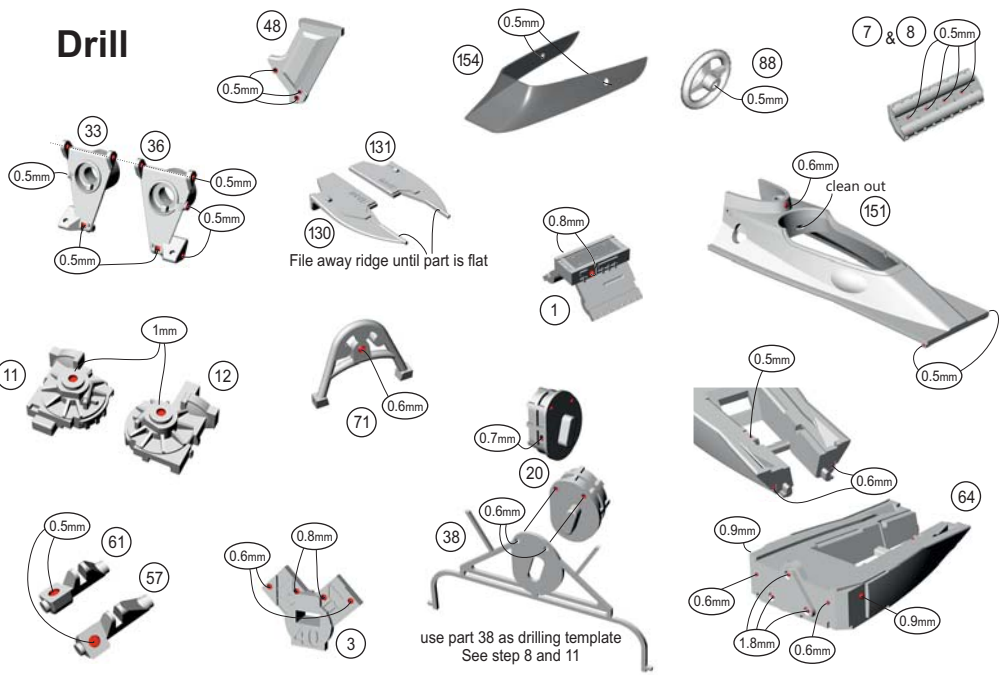
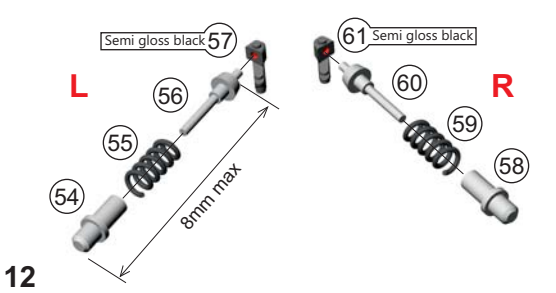
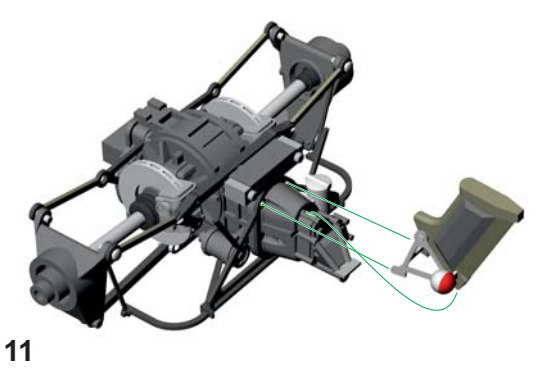
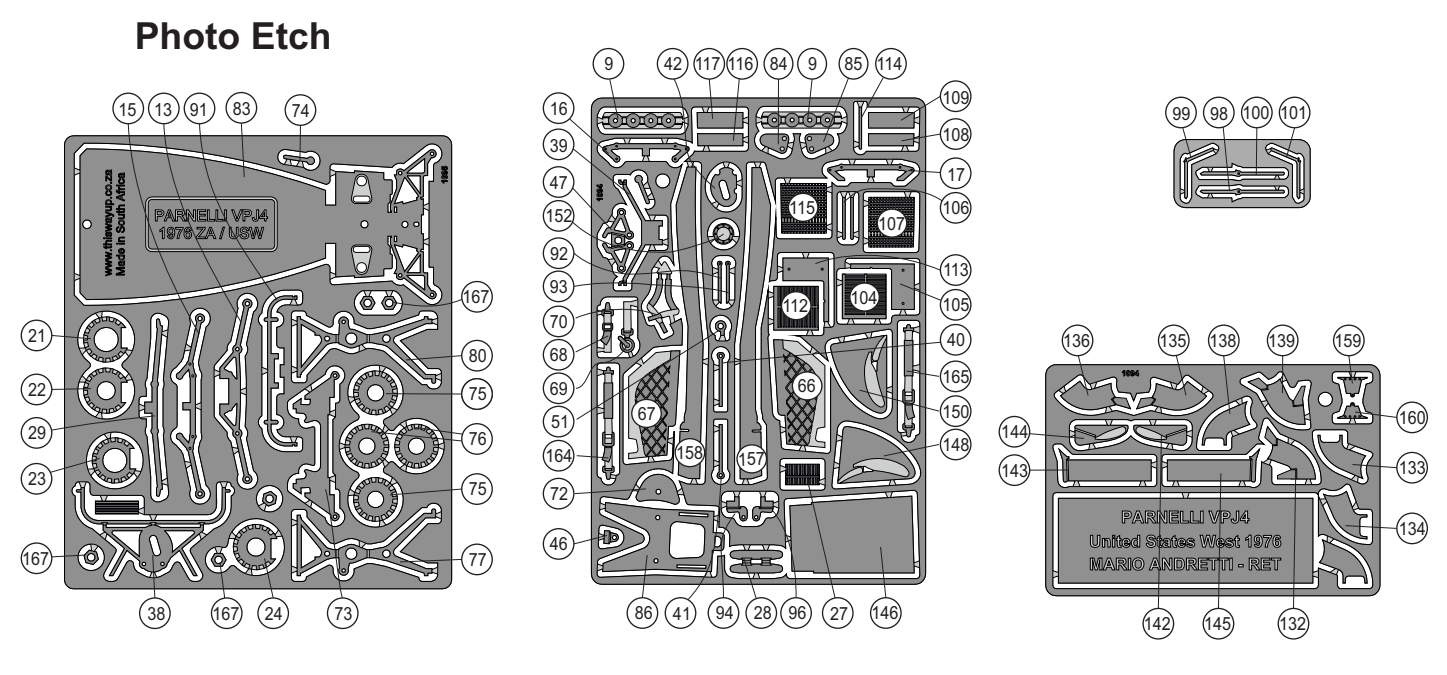
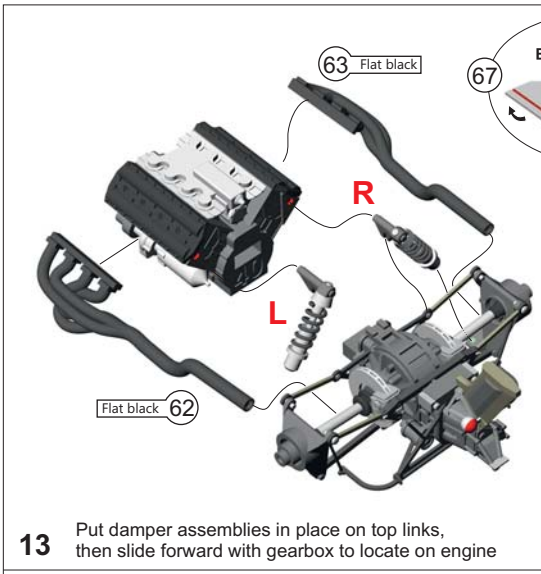
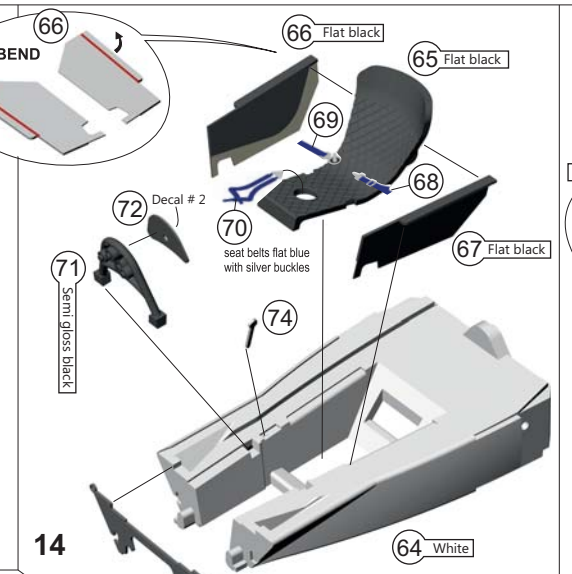

Photo Etch





13 Put damper assemblies in place on top links, then slide forward with gearbox to locate on engine



14

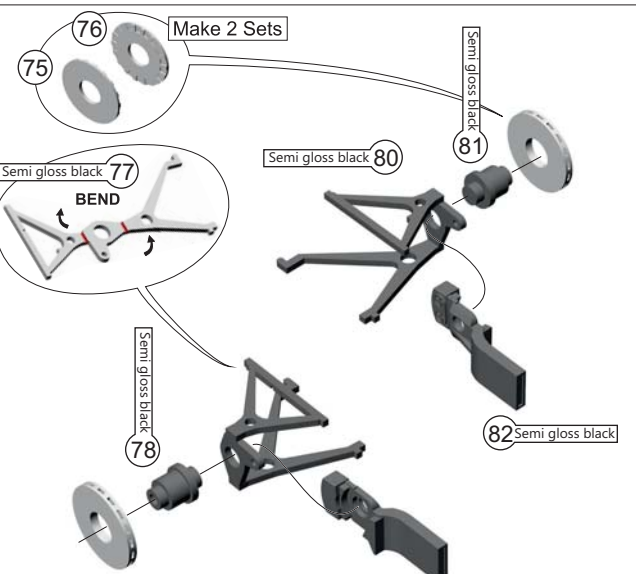

15

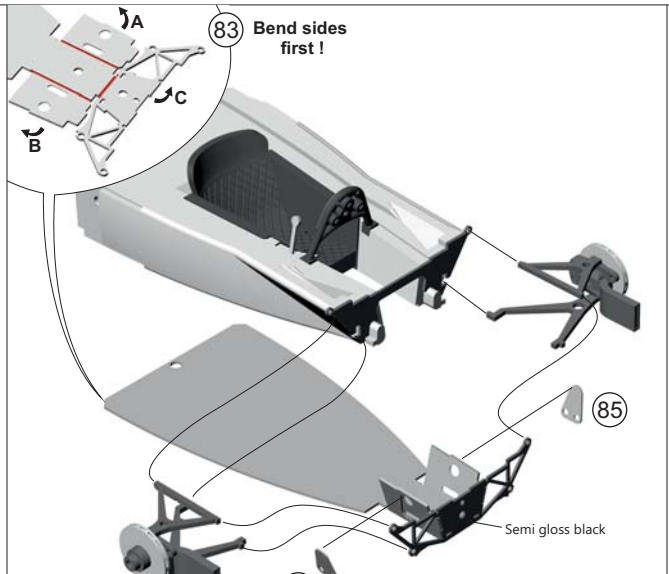

16

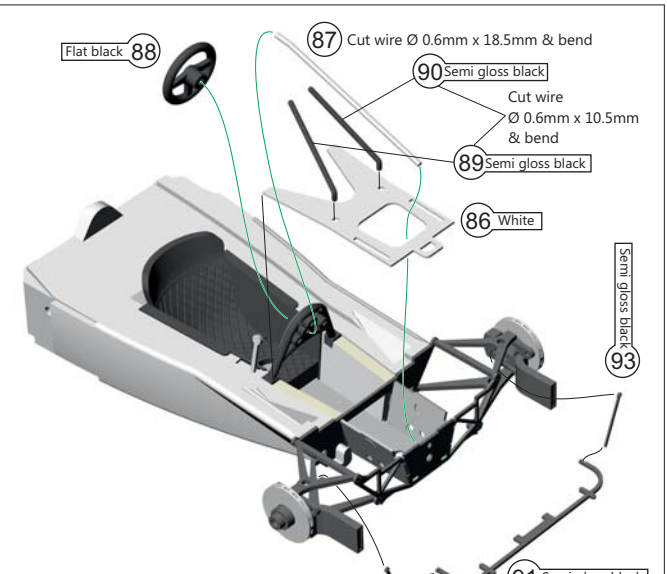

17

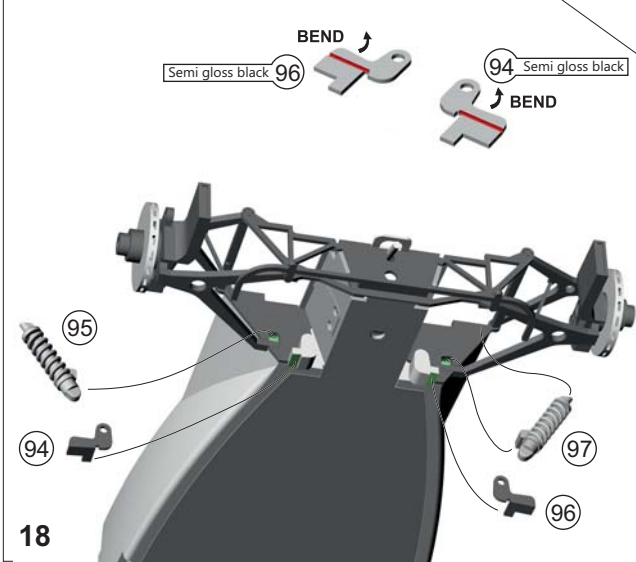

18

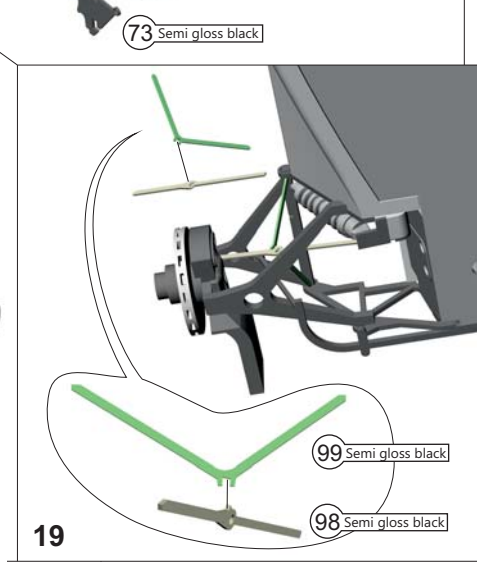

19

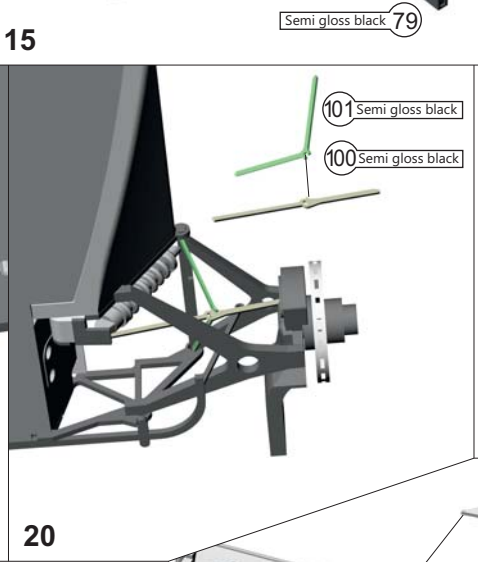

20

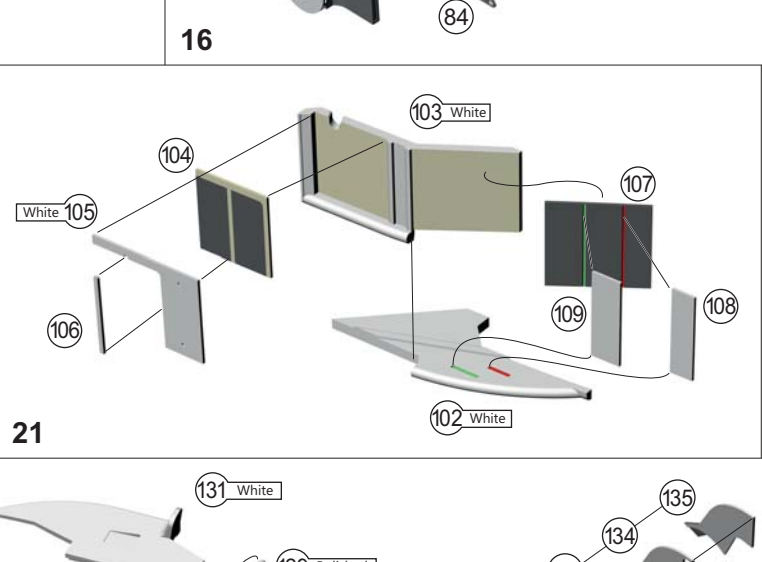

21

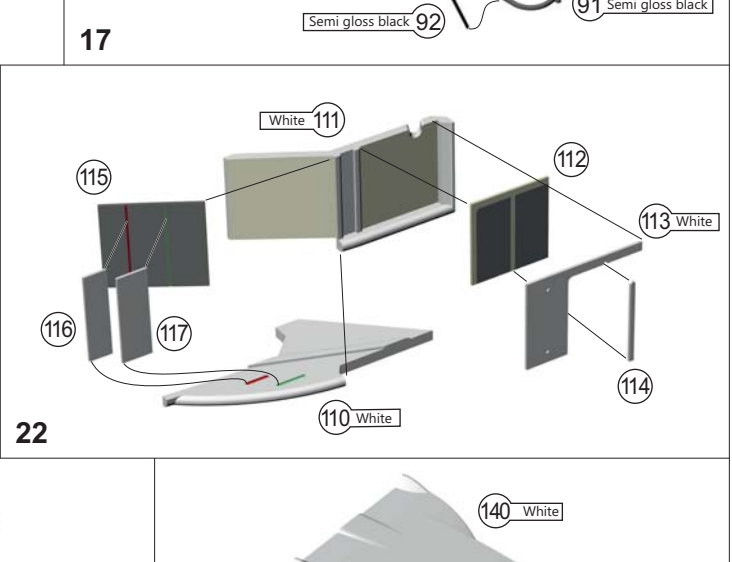

22

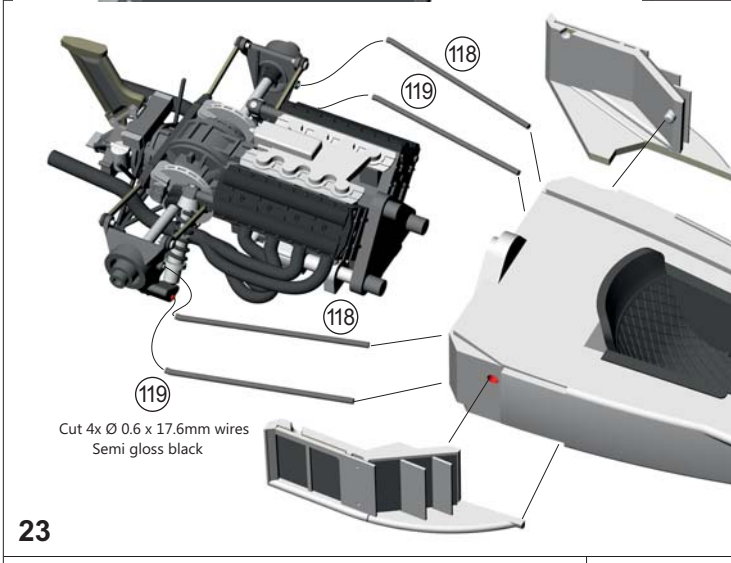

23

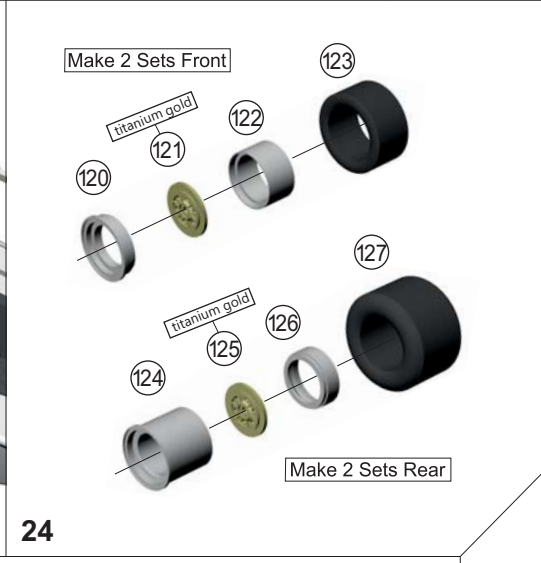

24

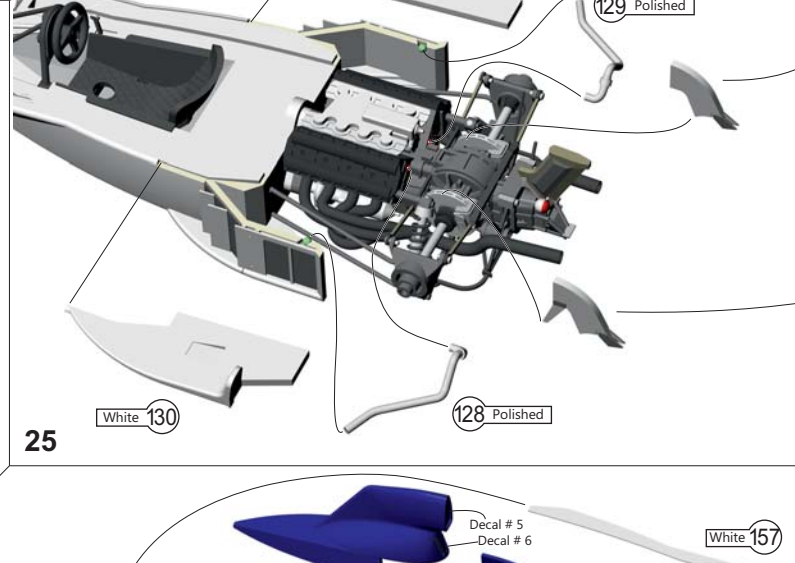

25

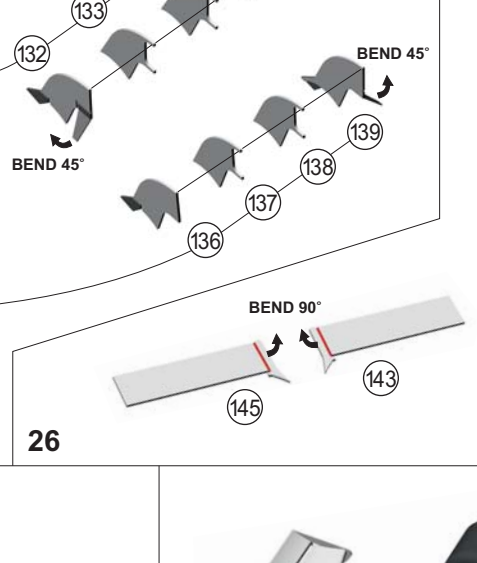

26

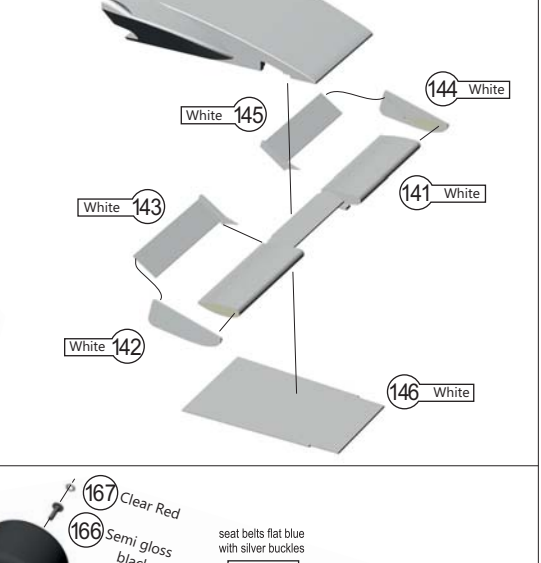

27

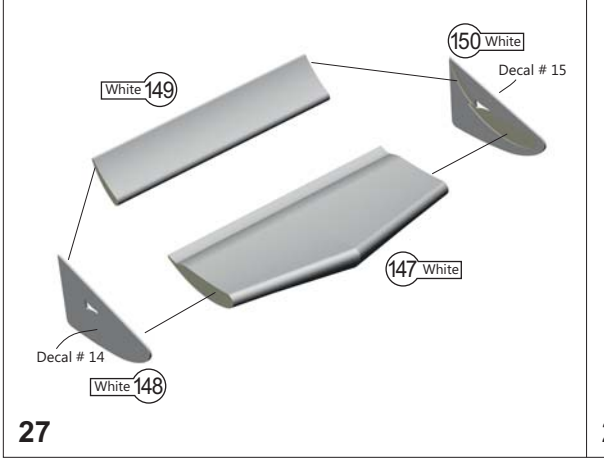

28

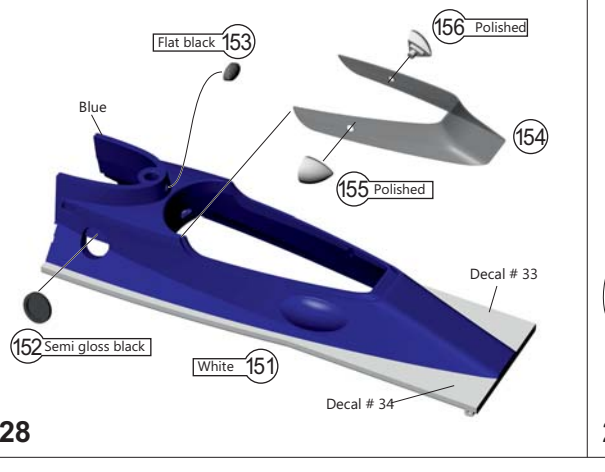

29 Cockpit surround in position first.

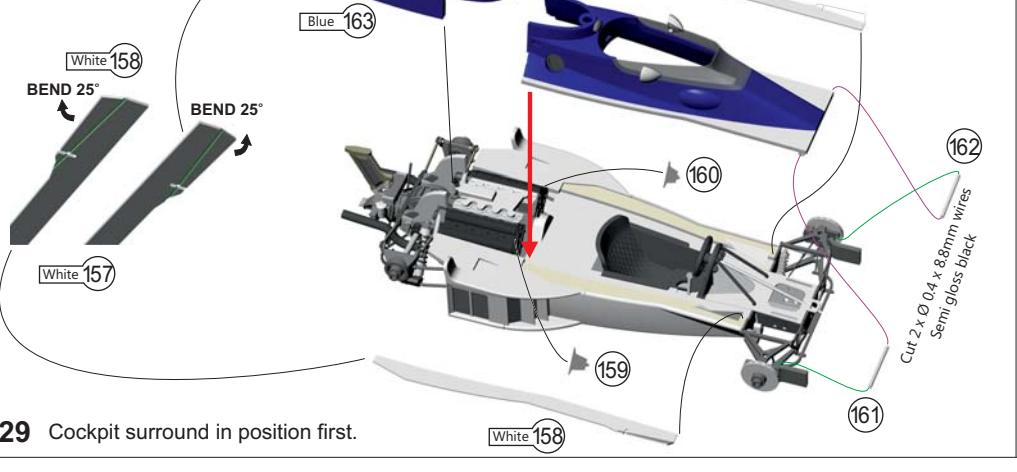

30

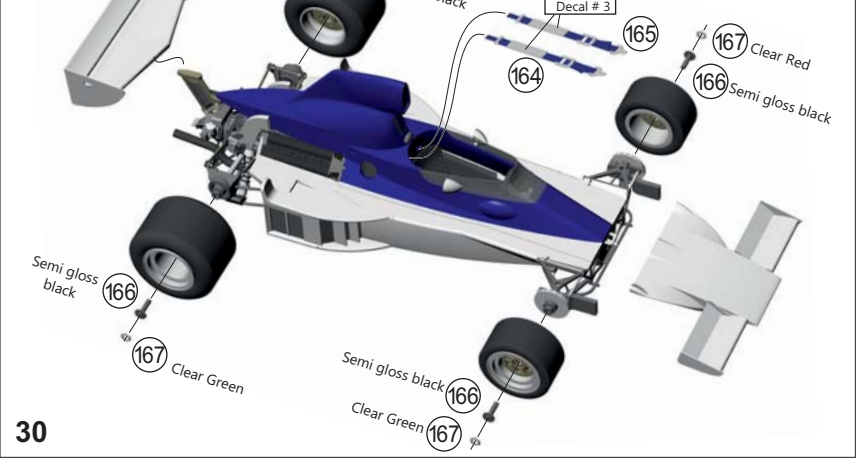

31